

Before deflashing

Rosler JDWB 12x4/2 Portable Wire Mesh Belt Conveyor Deflashing Machine

Portable Deflashing machine removes flash from medium sized thermoset plastic molded parts. Equipped with casters to allow the machine to be moved from press to press if required, easy integration at each molding press.

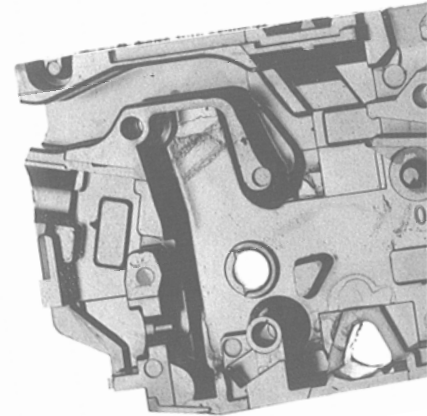

After deflashing



JDWB 12x4/2 Deflashing Machine

Part Capacity:

- line speed: 2-20 ft/min (0.5-6.0 m/min)
- max. part size: 1 ft 5 inch (432 mm) wide by 4 inch (100 mm) high
- max. blast work area: 12 inch (300 mm) wide by 4 inch (100 mm) high

Overall dimensions:

2 ft 6 inch (762 mm) wide x 10 ft 10 11/16 inch (3320 mm) long x 7 ft 10 5/16 inch (2396 mm) high

Machine features:

- two 5 hp direct drive wheels; one in downblast position, and one in upblast position, with individual variable speed control
- viewing window and light inside cabinet
- continuous 12 inch wide wire mesh belt conveyor
- optional hold down belt to secure lightweight parts during transport through the machine, synchronized with main conveyor belt.
- rotary drum screen for media cleansing
- anti-static system controls the static charge of the media
- integrated media blow-off system
- automatic media adder
- integrated reverse pulse cartridge dust collector
- integrated electrical control panel with PLC control with operator interface

